

LM3310

Step-Up PWM DC/DC Converter with Integrated Op-Amp and Gate Pulse Modulation Switch

General Description

The LM3310 is a step-up DC/DC converter integrated with an Operational Amplifier and a gate pulse modulation switch. The boost (step-up) converter is used to generate an adjustable output voltage and features a low $R_{DS(ON)}$ internal switch for maximum efficiency. The operating frequency is selectable between 660kHz and 1.28MHz allowing for the use of small external components. An external soft-start pin enables the user to tailor the soft-start time to a specific application and limit the inrush current. The Op-Amp is capable of sourcing/sinking 135mA of current (typical). The gate pulse modulation switch can operate with a VGH voltage of 5V to 30V. The LM3310 is available in a low profile 24-lead LLP package.

Features

- Boost converter with a 2A, 0.18 Ω switch
- Boost output voltage adjustable up to 20V
- Operating voltage range of 2.5V to 7V
- 660kHz/1.28MHz pin selectable switching frequency
- Adjustable soft-start function
- Input undervoltage protection
- Over temperature protection
- Integrated Op-Amp
- Integrated gate pulse modulation (GPM) switch
- 24-Lead LLP package

Applications

- TFT Bias Supplies
- Portable Applications

Typical Application Circuit

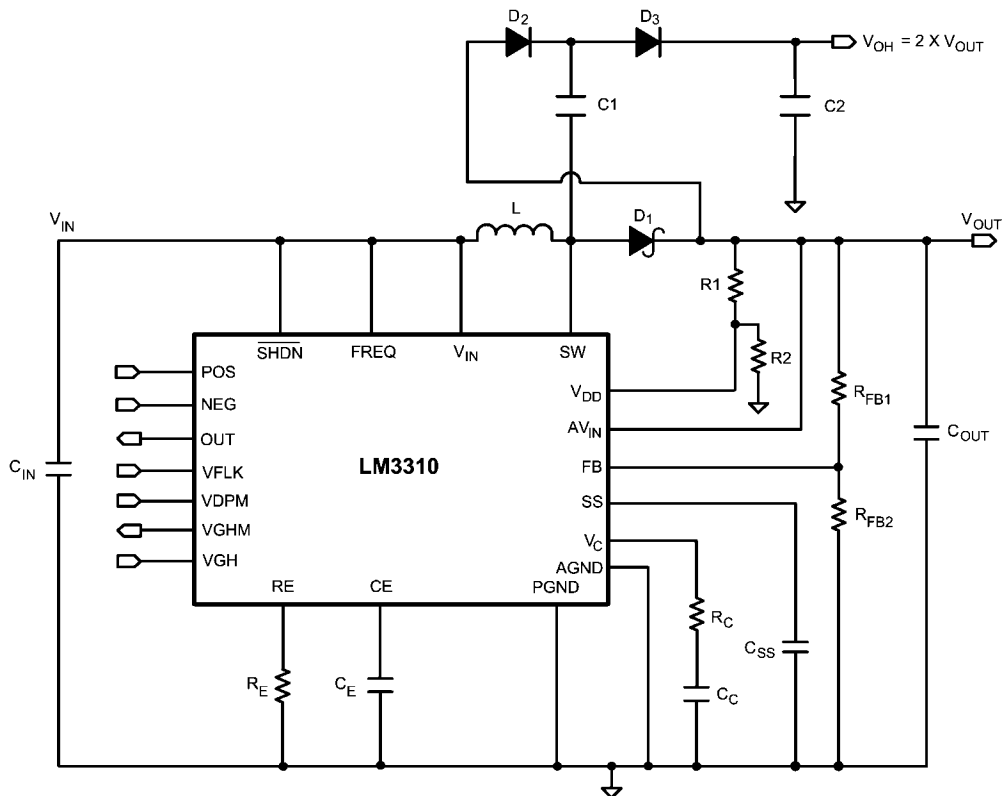

20133331

Connection Diagram

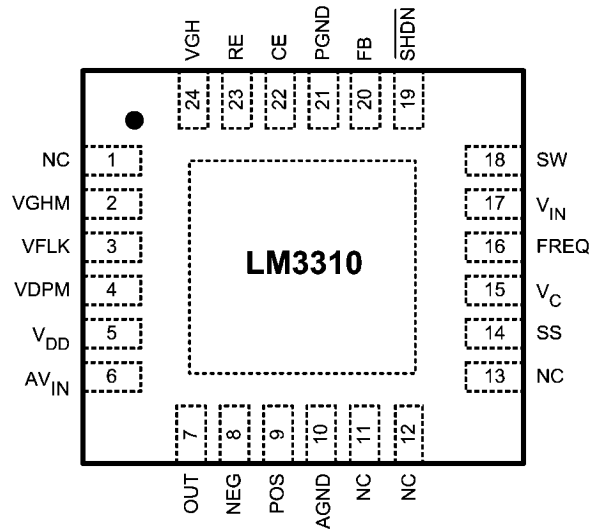

LLP-24 (Top View)
 $\theta_{JA}=37^{\circ}\text{C/W}$

20133304

Ordering Information

Order Number	Spec.	Package Type	NSC Package Drawing	Supplied As
LM3310SQ		LLP-24	SQA24A	1000 units/reel tape and reel
LM3310SQX		LLP-24	SQA24A	4500 units/reel tape and reel
LM3310SQ	NOPB	LLP-24	SQA24A	1000 units/reel tape and reel
LM3310SQX	NOPB	LLP-24	SQA24A	4500 units/reel tape and reel

Pin Descriptions

Pin	Name	Function
1	NC	Not internally connected. Leave pin open.
2	VGHM	Output of GPM circuit. This output directly drives the supply for the gate driver circuits.
3	VFLK	Determines when the TFT LCD is on or off. This is controlled by the timing controller in the LCD module.
4	VDPM	VDPM pin is the enable signal for the GPM block. Pulling this pin high enables the GPM while pulling this pin low disables it. VDPM is used for timing sequence control.
5	V _{DD}	Reference input for gate pulse modulation (GPM) circuit. The voltage at V _{DD} is used to set the lower VGHM voltage. If the GPM function is not used connect V _{DD} to V _{IN} .
6	AV _{IN}	Op-Amp analog power input.
7	OUT	Output of the Op-Amp.
8	NEG	Negative input terminal of the Op-Amp.
9	POS	Positive input terminal of the Op-Amp.
10	AGND	Analog ground for the step-up regulator, LDO, and Op-Amp. Connect directly to DAP and PGND beneath the device.
11	NC	Not internally connected. Leave pin open.
12	NC	Not internally connected. Leave pin open.
13	NC	Not internally connected. Leave pin open.

Pin	Name	Function
14	SS	Boost converter soft start pin.
15	V _C	Boost compensation network connection. Connected to the output of the voltage error amplifier.
16	FREQ	Switching frequency select input. Connect this pin to V _{IN} for 1.28MHz operation and AGND for 660kHz operation.
17	V _{IN}	Boost converter and GPM power input.
18	SW	Boost power switch input. Switch connected between SW pin and PGND pin.
19	SHDN	Shutdown pin. Active low, pulling this pin low disable the LM3310.
20	FB	Boost output voltage feedback input.
21	PGND	Power Ground. Source connection of the step-up regulator NMOS switch and ground for the GPM circuit. Connect AGND and PGND directly to the DAP beneath the device.
22	CE	Connect capacitor from this pin to AGND.
23	RE	Connect a resistor between RE and PGND.
24	VGH	GPM power supply input. VGH range is 5V to 30V.
DAP		Die Attach Pad. Internally connected to GND. Connect AGND and PGND pins directly to this pad beneath the device.

Block Diagrams

Boost Converter

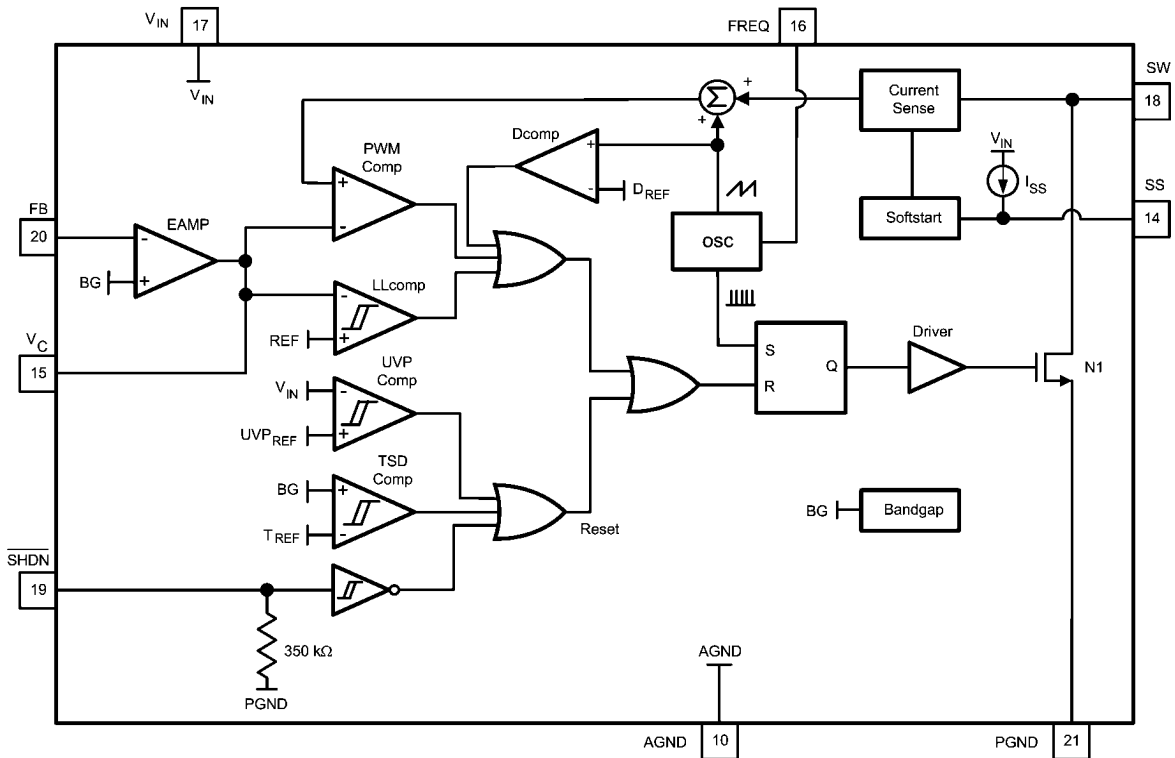

20133357

GPM Block

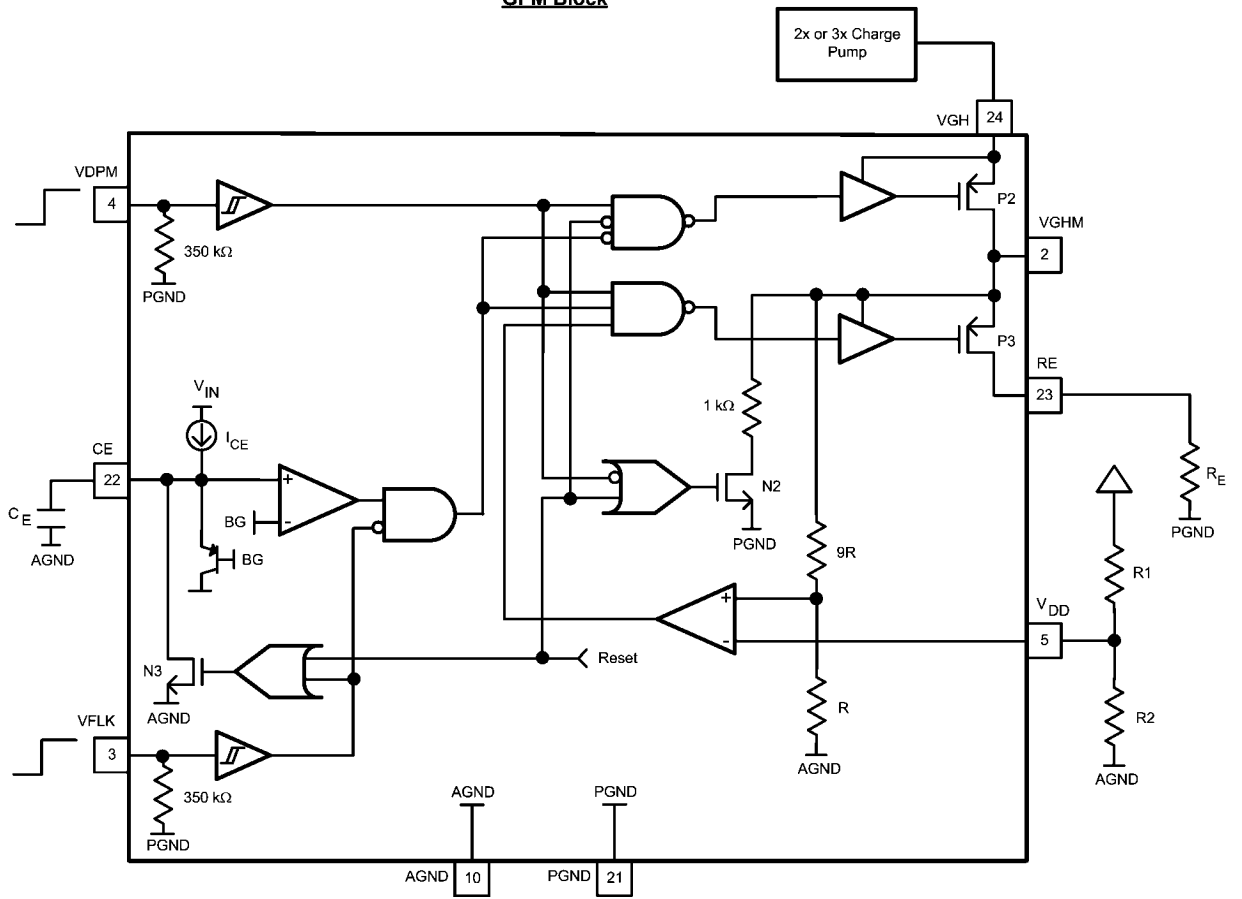

20133358

Op-Amp

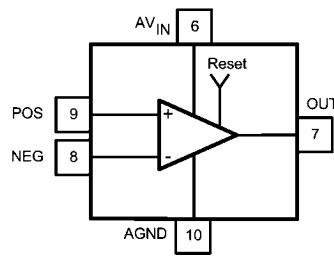

20133359

Absolute Maximum Ratings (Note 1)

If Military/Aerospace specified devices are required, please contact the National Semiconductor Sales Office/Distributors for availability and specifications.

V_{IN}	7.5V
SW Voltage	21V
FB Voltage	V_{IN}
V_C Voltage (Note 2)	$1.265V \pm 0.3V$
\overline{SHDN} Voltage	7.5V
FREQ	V_{IN}
AV_{IN}	14.5V
Amplifier Inputs/Output	Rail-to-Rail
VGH Voltage	31V
VGHM Voltage	VGH
VFLK, VDPM, V_{DD} Voltage	7.5V
CE Voltage (Note 2)	$1.265 + 0.3V$
RE Voltage	VGH

Maximum Junction Temperature	150°C
Power Dissipation (Note 3)	Internally Limited
Lead Temperature	300°C
Vapor Phase (60 sec.)	215°C
Infrared (15 sec.)	220°C
ESD Susceptibility (Note 4)	
Human Body Model	2kV

Operating Conditions

Operating Junction Temperature Range (Note 5)	-40°C to +125°C
Storage Temperature	-65°C to +150°C
Supply Voltage	2.5V to 7V
Maximum SW Voltage	20V
VGH Voltage Range	5V to 30V
Op-Amp Supply, AV_{IN}	4V to 14V

Electrical Characteristics

Specifications in standard type face are for $T_J = 25^\circ\text{C}$ and those with **boldface type** apply over the full **Operating Temperature Range** ($T_J = -40^\circ\text{C}$ to $+125^\circ\text{C}$). Unless otherwise specified, $V_{IN} = 2.5\text{V}$ and $I_L = 0\text{A}$.

Symbol	Parameter	Conditions	Min (Note 5)	Typ (Note 6)	Max (Note 5)	Units
I_Q	Quiescent Current	FB = 2V (Not Switching)		690	1100	μA
		$V_{\overline{SHDN}} = 0\text{V}$		0.04	0.5 8.5	
		660kHz Switching		2.1	2.8	mA
		1.28MHz Switching		3.1	4.0	
V_{FB}	Feedback Voltage		1.231	1.263	1.287	V
$\%V_{FB}/\Delta V_{IN}$	Feedback Voltage Line Regulation	$2.5\text{V} \leq V_{IN} \leq 7\text{V}$	-0.26	0.089	0.42	%/V
I_{CL}	Switch Current Limit (Note 7)	(Note 8)	2.0	2.6		A
I_B	FB Pin Bias Current (Note 9)			27	160	nA
I_{SS}	SS Pin Current		8.5	11	13.5	μA
V_{SS}	SS Pin Voltage		1.20	1.24	1.28	V
V_{IN}	Input Voltage Range		2.5		7	V
g_m	Error Amp Transconductance	$\Delta I = 5\mu\text{A}$	26	74	133	μmho
A_V	Error Amp Voltage Gain			69		V/V
D_{MAX}	Maximum Duty Cycle	$f_S = 660\text{kHz}$	80	91		%
		$f_S = 1.28\text{MHz}$	80	89		
f_S	Switching Frequency	FREQ = Ground	440	660	760	kHz
		FREQ = V_{IN}	1.0	1.28	1.5	MHz
$I_{\overline{SHDN}}$	Shutdown Pin Current	$V_{\overline{SHDN}} = 2.5\text{V}$		8	13.5	μA
		$V_{\overline{SHDN}} = 0.3\text{V}$		1	2	
I_L	Switch Leakage Current	$V_{SW} = 20\text{V}$		0.03	5	μA
R_{DSON}	Switch R_{DSON}	$I_{SW} = 500\text{mA}$		0.18	0.35	Ω
$Th_{\overline{SHDN}}$	\overline{SHDN} Threshold	Output High, $V_{IN} = 2.5\text{V}$ to 7V	1.4			V
		Output Low, $V_{IN} = 2.5\text{V}$ to 7V			0.4	
UVP	Undervoltage Protection Threshold	On Threshold (Switch On)	2.5	2.4		V
		Off Threshold (Switch Off)		2.3	2.1	
I_{FREQ}	FREQ Pin Current	FREQ = $V_{IN} = 2.5\text{V}$		2.7	13.5	μA

Electrical Characteristics

Specifications in standard type face are for $T_J = 25^\circ\text{C}$ and those with **boldface type** apply over the full **Operating Temperature Range** ($T_J = -40^\circ\text{C}$ to $+125^\circ\text{C}$). Unless otherwise specified $V_{IN} = 2.5\text{V}$ and $AV_{IN} = 8\text{V}$.

Operational Amplifier

Symbol	Parameter	Conditions	Min(Note 5)	Typ(Note 6)	Max(Note 5)	Units
V_{OS}	Input Offset Voltage	Buffer configuration, $V_O = AV_{IN}/2$, no load		5.7	15	mV
I_B	Input Bias Current (POS Pin)	Buffer configuration, $V_O = AV_{IN}/2$, no load (Note 9)		200	550	nA
V_{OUT} Swing		Buffer, $R_L = 2\text{k}\Omega$, V_O min.		0.001	0.03	V
		Buffer, $R_L = 2\text{k}\Omega$, V_O max.	7.9	7.97		
AV_{IN}	Supply Voltage		4		14	V
I_{S+}	Supply Current	Buffer, $V_O = AV_{IN}/2$, No Load		1.5	7.8	mA
I_{OUT}	Output Current	Source	90	138	195	mA
		Sink	105	135	175	

Electrical Characteristics

Specifications in standard type face are for $T_J = 25^\circ\text{C}$ and those with **boldface type** apply over the full **Operating Temperature Range** ($T_J = -40^\circ\text{C}$ to $+125^\circ\text{C}$). Unless otherwise specified $V_{IN} = 2.5\text{V}$.

Gate Pulse Modulation

Symbol	Parameter	Conditions	Min(Note 5)	Typ(Note 6)	Max(Note 5)	Units
VFLK	VFLK Voltage Levels	Rising edge threshold			1.4	V
		Falling edge threshold	0.4			
VDPM	VDPM Voltage Levels	Rising edge threshold			1.4	V
		Falling edge threshold	0.4			
$V_{DD(TH)}$	V_{DD} Threshold	VGHM = 30V	2.8	3	3.3	V
		VGHM = 5V	0.4	0.5	0.7	
I_{VFLK}	VFLK Current	VFLK = 1.5V		4.8	11	μA
		VFLK = 0.3V		1.1	2.5	
I_{VDPM}	VDPM Current	VDPM = 1.5V		4.8	11	μA
		VDPM = 0.3V		1.1	2.5	
I_{VGH}	VGH Bias Current	VGH = 30V, VFLK High		59	300	μA
		VGH = 30V, VFLK Low		11	35.5	
$R_{VGH-VGHM}$	VGH to VGHM Resistance	20mA Current, VGH = 30V		14	28.5	Ω
$R_{VGHM-RE}$	VGHM to RE Resistance	20mA Current, VGH = VGHM = 30V		27	55	
$R_{VGHM(OFF)}$	VGH Resistance	VDPM is Low, VGHM = 2V		1.2	1.7	k Ω
I_{CE}	CE Current	CE = 0V	7	11	16	μA
$V_{CE(TH)}$	CE Voltage Threshold		1.16	1.22	1.34	V

Note 1: Absolute maximum ratings are limits beyond which damage to the device may occur. Operating Ratings are conditions for which the device is intended to be functional, but device parameter specifications may not be guaranteed. For guaranteed specifications and test conditions, see the Electrical Characteristics.

Note 2: Under normal operation the V_C and CE pins may go to voltages above this value. The maximum rating is for the possibility of a voltage being applied to the pin, however the V_C and CE pins should never have a voltage directly applied to them.

Note 3: The maximum allowable power dissipation is a function of the maximum junction temperature, $T_J(\text{MAX})$, the junction-to-ambient thermal resistance, θ_{JA} , and the ambient temperature, T_A . See the Electrical Characteristics table for the thermal resistance of various layouts. The maximum allowable power dissipation at any ambient temperature is calculated using: $P_D(\text{MAX}) = (T_{J(\text{MAX})} - T_A)/\theta_{JA}$. Exceeding the maximum allowable power dissipation will cause excessive die temperature, and the regulator will go into thermal shutdown.

Note 4: The human body model is a 100pF capacitor discharged through a 1.5k Ω resistor into each pin per JEDEC standard JESD22-A114.

Note 5: All limits guaranteed at room temperature (standard typeface) and at temperature extremes (bold typeface). All room temperature limits are 100% production tested. All limits at temperature extremes are guaranteed via correlation using standard Statistical Quality Control (SQC) methods. All limits are used to calculate Average Outgoing Quality Level (AOQL).

Note 6: Typical numbers are at 25°C and represent the most likely norm.

Note 7: Duty cycle affects current limit due to ramp generator.

Note 8: Current limit at 0% duty cycle. See TYPICAL PERFORMANCE section for Switch Current Limit vs. V_{IN}

Note 9: Bias current flows into pin.

Typical Performance Characteristics

SHDN Pin Current vs. SHDN Pin Voltage

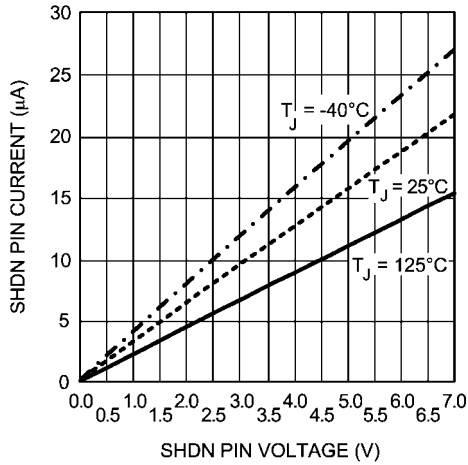

20133361

SS Pin Current vs. Input Voltage

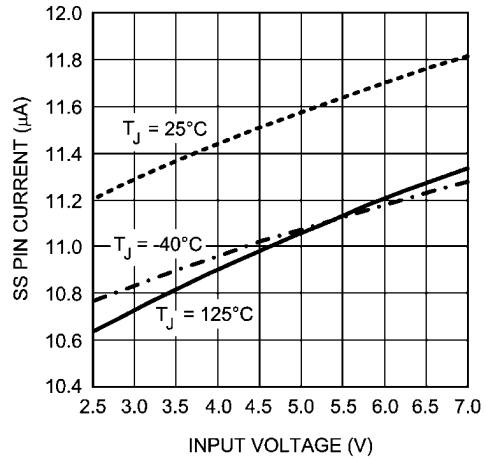

20133362

FREQ Pin Current vs. Input Voltage

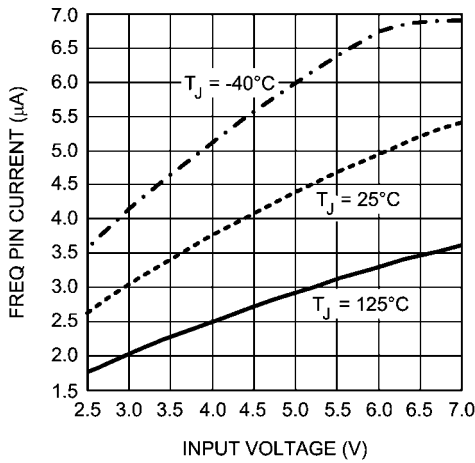

20133363

FB Pin Current vs. Temperature

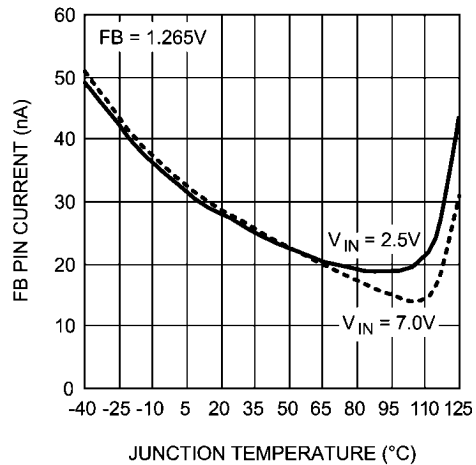

20133364

CE Pin Current vs. Input Voltage

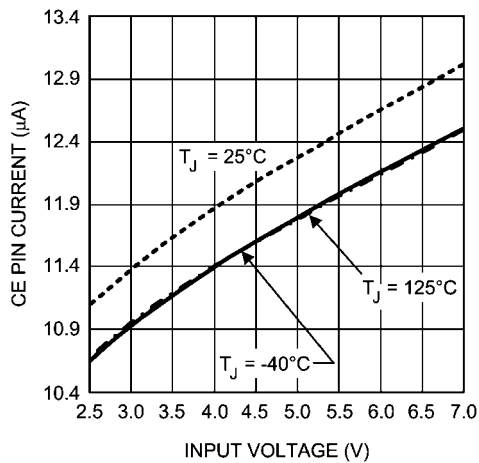

20133360

VDPM Pin Current vs. VDPM Pin Voltage

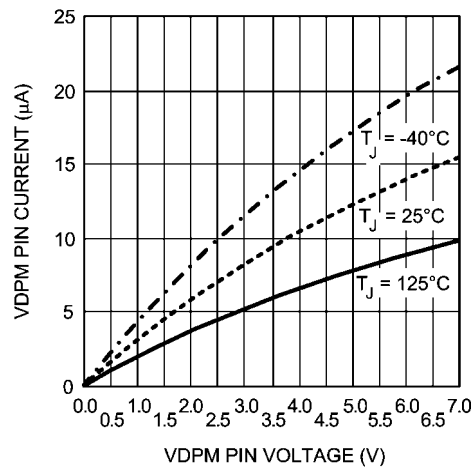

20133365

VFLK Pin Current vs. VFLK Pin Voltage

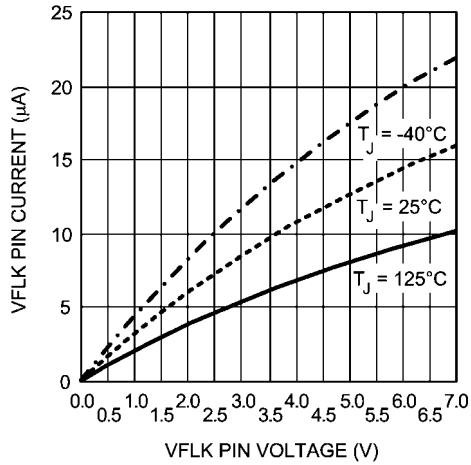

20133366

660kHz Switching Quiescent Current vs. Input Voltage

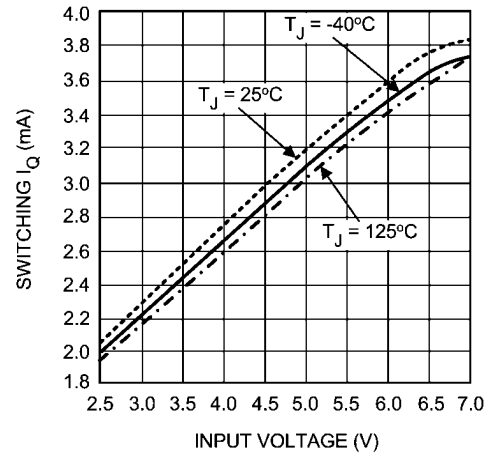

20133387

1.28MHz Switching Quiescent Current vs. Input Voltage

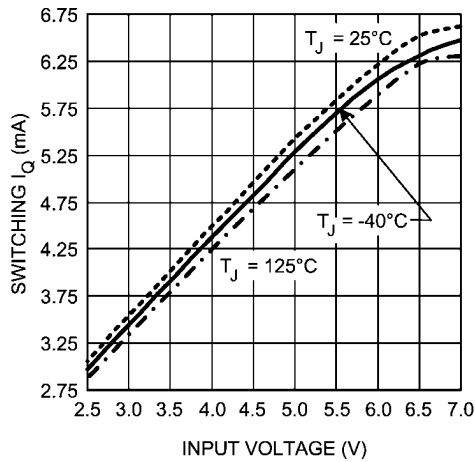

20133367

660kHz Switching Quiescent Current vs. Temperature

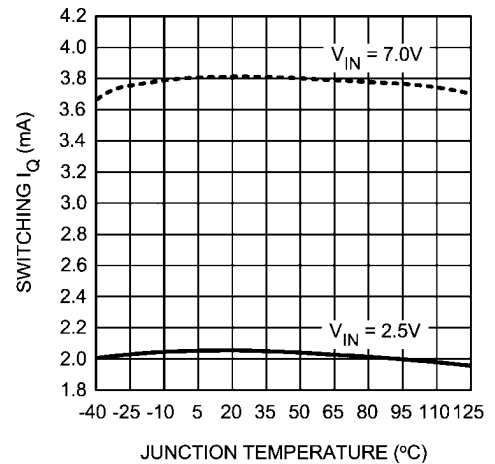

20133388

1.28MHz Switching Quiescent Current vs. Temperature

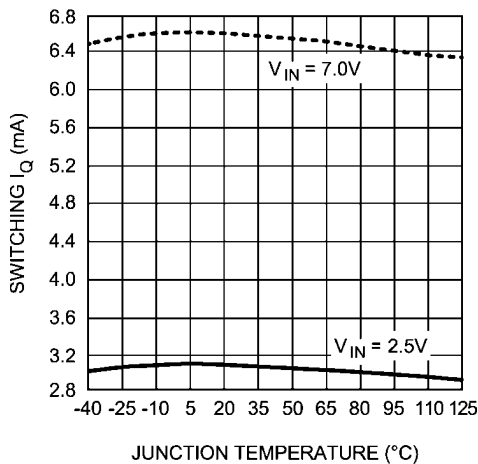

20133368

660kHz Switching Frequency vs. Temperature

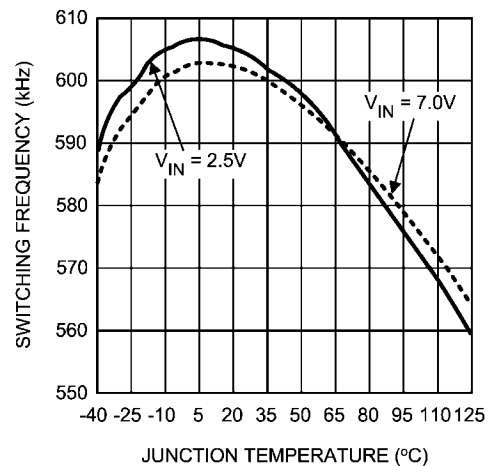

20133389

1.28MHz Switching Frequency vs. Temperature

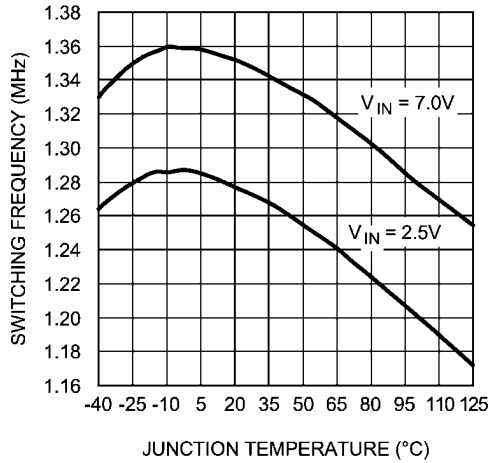

20133369

Switch Current Limit vs. Input Voltage

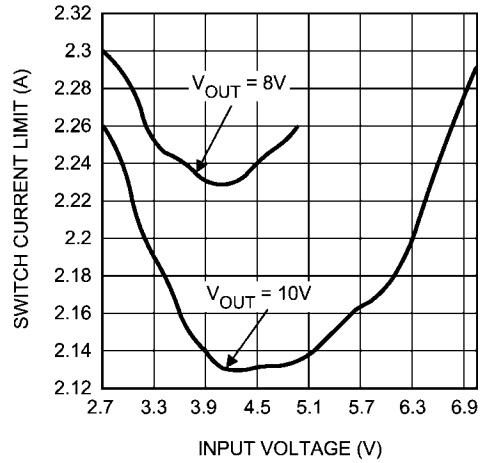

20133319

Non-Switching Quiescent Current vs. Input Voltage
GPM Disabled

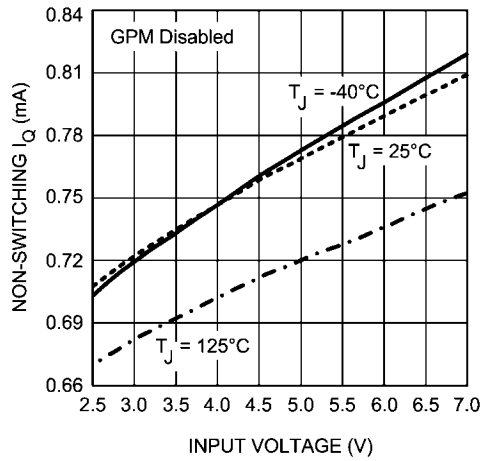

20133371

Non-Switching Quiescent Current vs. Input Voltage
GPM Enabled

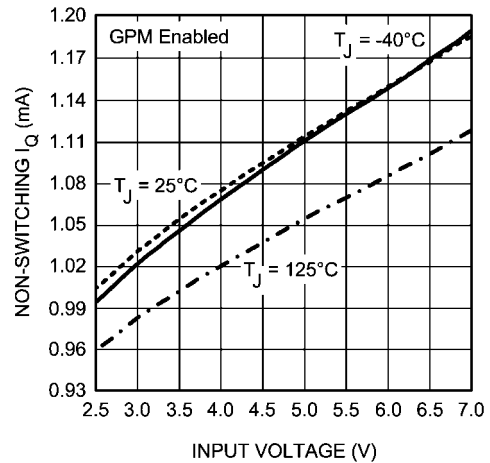

20133372

Non-Switching Quiescent Current vs. Temperature
GPM Disabled

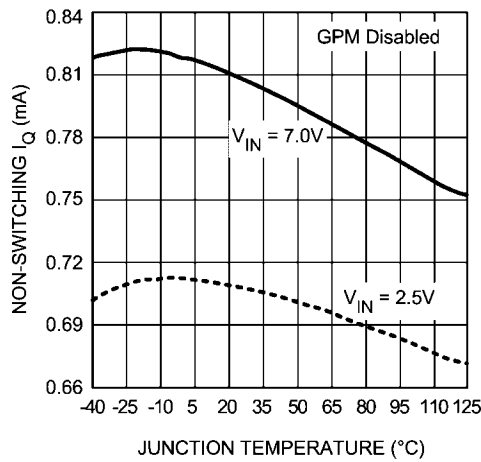

20133373

Non-Switching Quiescent Current vs. Temperature
GPM Enabled

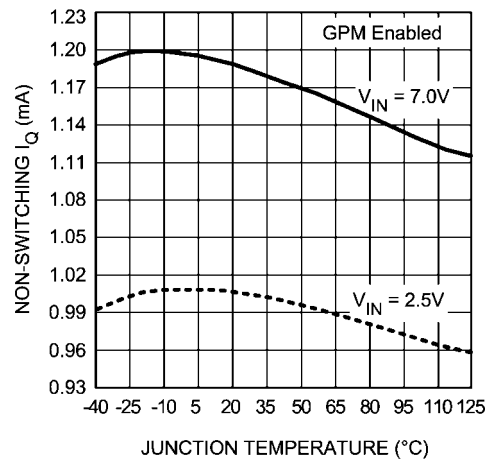

20133374

Power NMOS $R_{DS(on)}$ vs. Input Voltage

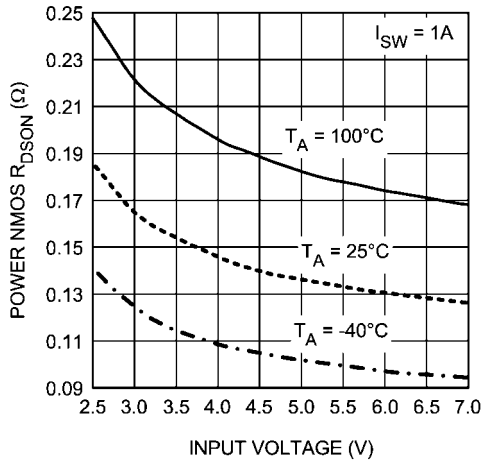

20133375

660kHz Max. Duty Cycle vs. Input Voltage

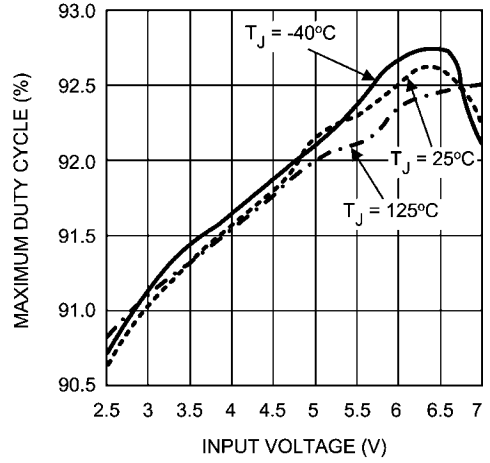

20133391

1.28MHz Max. Duty Cycle vs. Input Voltage

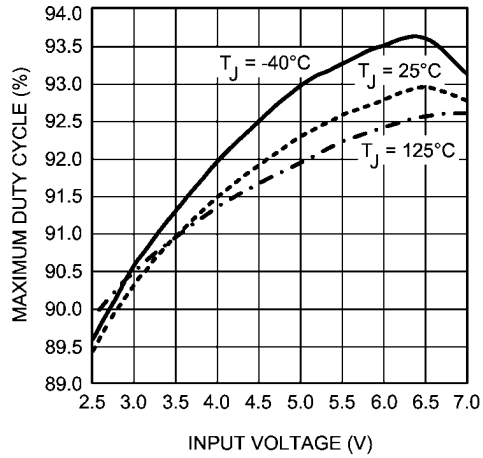

20133383

660kHz Max. Duty Cycle vs. Temperature

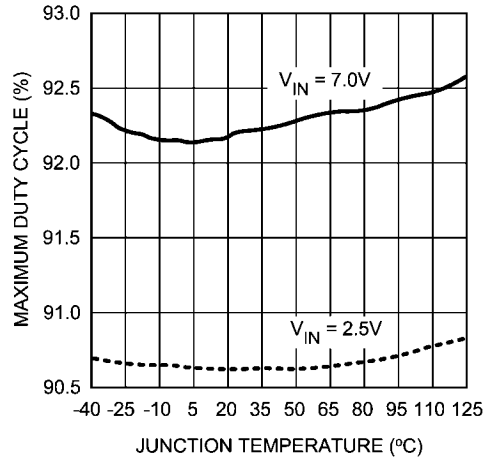

20133390

1.28MHz Max. Duty Cycle vs. Temperature

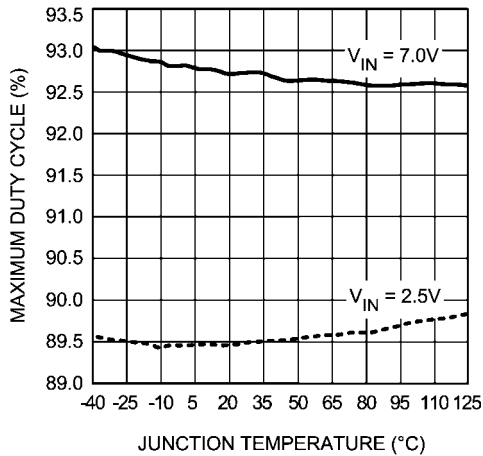

20133376

1.28MHz Application Efficiency

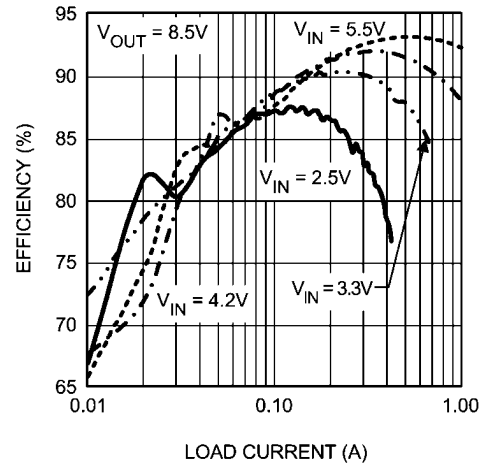

20133382

1.28MHz Application Efficiency

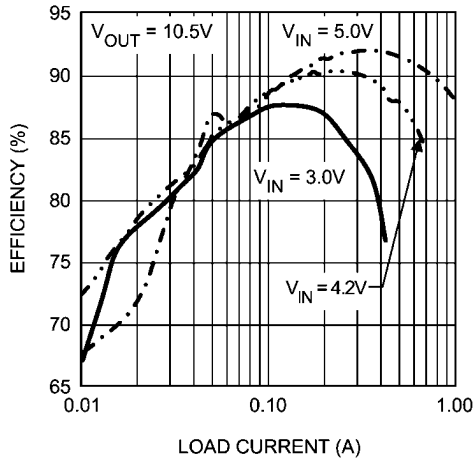

VGH Pin Bias Current vs. VGH Pin Voltage

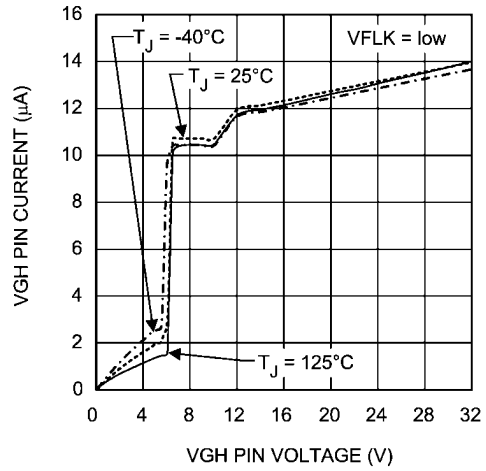

VGH Pin Bias Current vs. VGH Pin Voltage

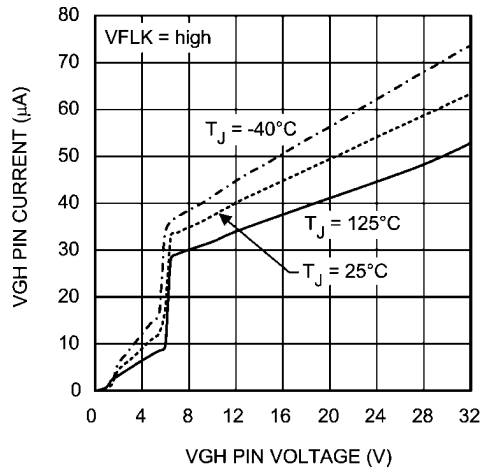

VGH-VGHM PMOS R_DS(on) vs. VGH Pin Voltage

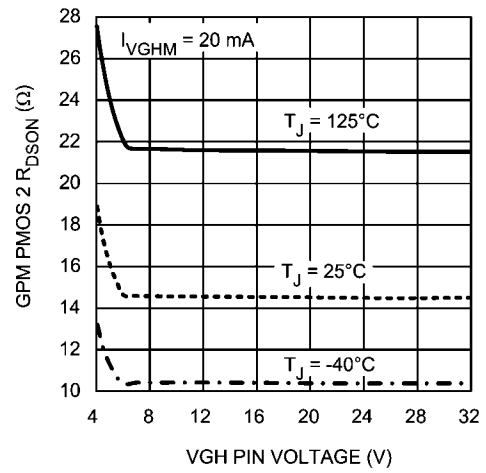

VGHM-RE PMOS R_DS(on) vs. VGHM Pin Voltage

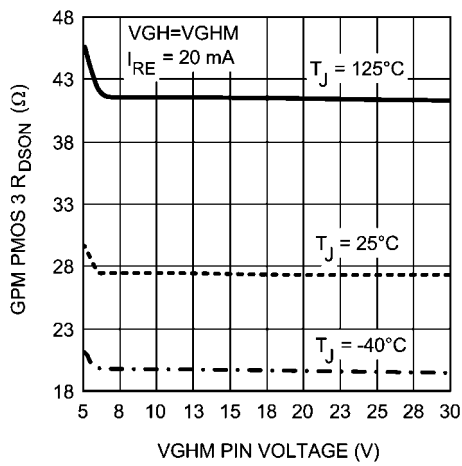

VGHM OFF Resistance vs. Temperature

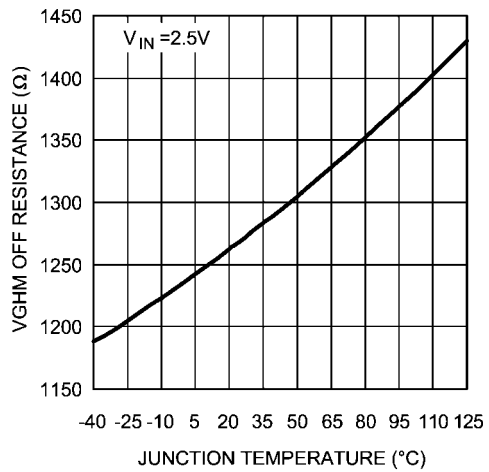

Op-Amp Source Current vs. AV_{IN}

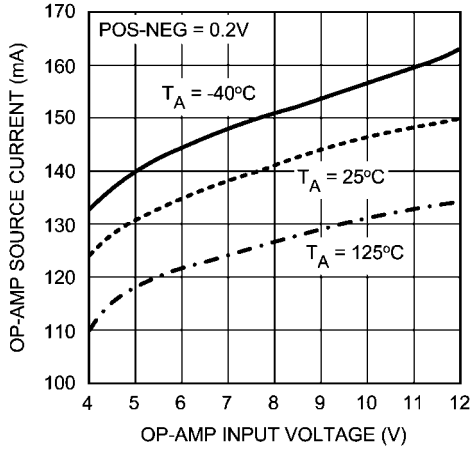

Op-Amp Sink Current vs. AV_{IN}

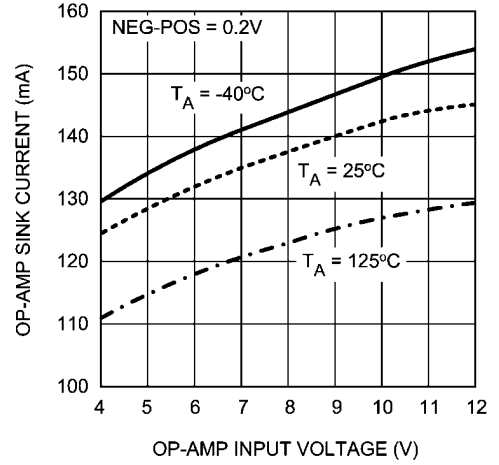

Op-Amp Quiescent Current vs. AV_{IN}

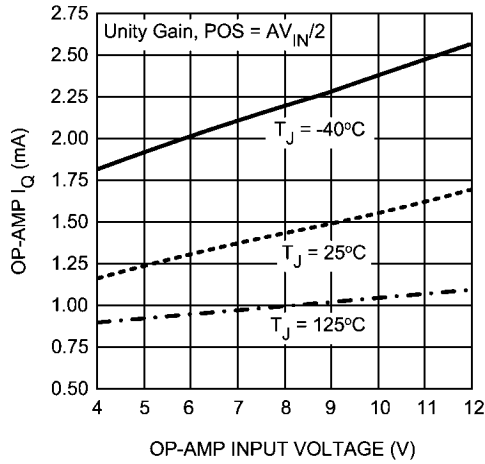

Op-Amp Offset Voltage vs. AV_{IN} (No Load)

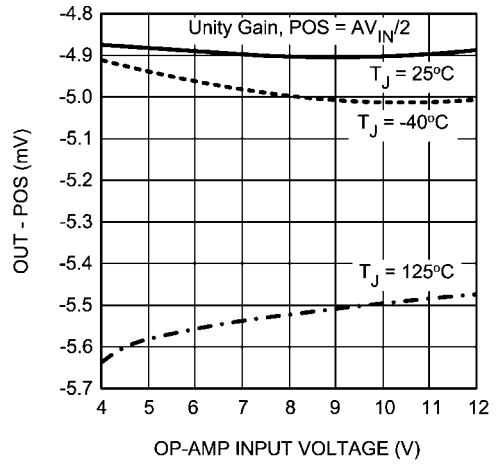

Op-Amp Offset Voltage vs. Load Current

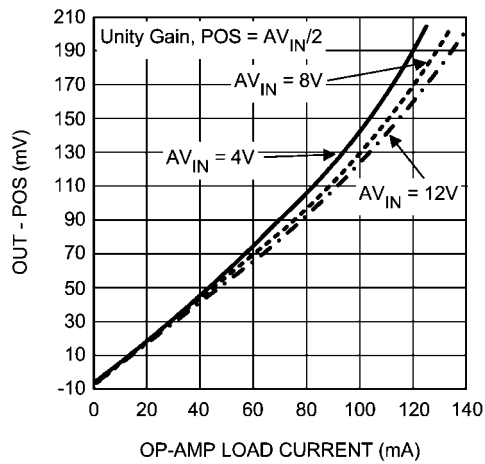

1.28MHz, 8.5V Application Boost Load Step

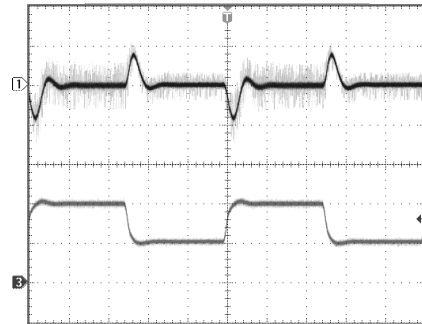

$V_{OUT} = 8.5V$, $V_{IN} = 3.3V$, $C_{OUT} = 20\mu F$
 1) V_{OUT} , 200mV/div, AC
 3) I_{LOAD} , 200mA/div, DC
 $T = 200\mu s/div$

1.28MHz, 8.5V Application Boost Startup Waveform

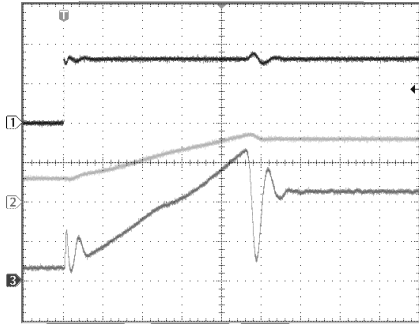

20133352

 $V_{OUT} = 8.5V$, $V_{IN} = 3.3V$, $C_{OUT} = 20\mu F$, $R_{LOAD} = 20\Omega$, $C_{SS} = 10nF$

- 1) V_{SHDN} , 2V/div, DC
 - 2) V_{OUT} , 5V/div, DC
 - 3) I_{IN} , 500mA/div, DC
- T = 200 μ s/div

1.28MHz, 8.5V Application Boost Startup Waveform

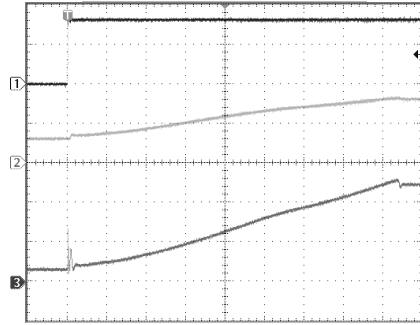

20133353

 $V_{OUT} = 8.5V$, $V_{IN} = 3.3V$, $C_{OUT} = 20\mu F$, $R_{LOAD} = 20\Omega$, $C_{SS} = 100nF$

- 1) V_{SHDN} , 2V/div, DC
 - 2) V_{OUT} , 5V/div, DC
 - 3) I_{IN} , 500mA/div, DC
- T = 1ms/div

1.28MHz, 8.5V Application Boost Startup Waveform

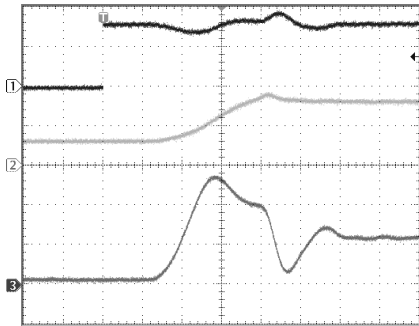

20133354

 $V_{OUT} = 8.5V$, $V_{IN} = 3.3V$, $C_{OUT} = 20\mu F$, $R_{LOAD} = 20\Omega$, $C_{SS} = \text{open}$

- 1) V_{SHDN} , 2V/div, DC
 - 2) V_{OUT} , 5V/div, DC
 - 3) I_{IN} , 1A/div, DC
- T = 40 μ s/div

Operation

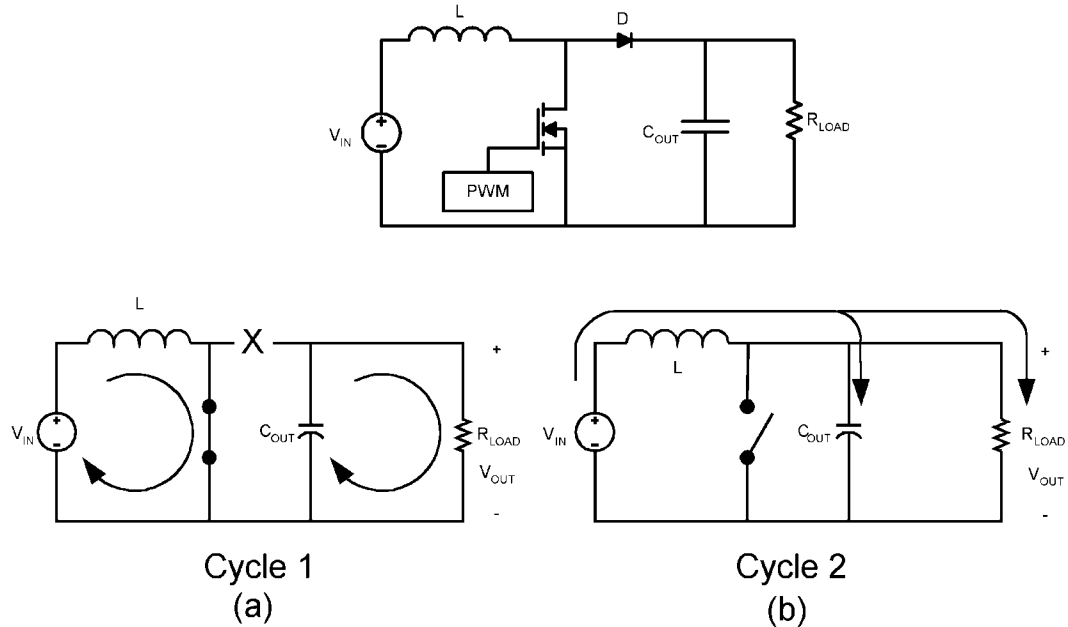

FIGURE 1. Simplified Boost Converter Diagram
(a) First Cycle of Operation (b) Second Cycle Of Operation

20133302

CONTINUOUS CONDUCTION MODE

The LM3310 contains a current-mode, PWM boost regulator. A boost regulator steps the input voltage up to a higher output voltage. In continuous conduction mode (when the inductor current never reaches zero at steady state), the boost regulator operates in two cycles.

In the first cycle of operation, shown in *Figure 1 (a)*, the transistor is closed and the diode is reverse biased. Energy is collected in the inductor and the load current is supplied by C_{OUT} .

The second cycle is shown in *Figure 1 (b)*. During this cycle, the transistor is open and the diode is forward biased. The energy stored in the inductor is transferred to the load and output capacitor.

The ratio of these two cycles determines the output voltage. The output voltage is defined approximately as:

$$V_{OUT} = \frac{V_{IN}}{1-D}, D' = (1-D) = \frac{V_{IN}}{V_{OUT}}$$

where D is the duty cycle of the switch, D and D' will be required for design calculations.

SETTING THE OUTPUT VOLTAGE (BOOST CONVERTER)

The output voltage is set using the feedback pin and a resistor divider connected to the output as shown in the typical operating circuit. The feedback pin voltage is 1.263V, so the ratio of the feedback resistors sets the output voltage according to the following equation:

$$R_{FB1} = R_{FB2} \times \frac{V_{OUT} - 1.263}{1.263} \Omega$$

SOFT-START CAPACITOR

The LM3310 has a soft-start pin that can be used to limit the inductor inrush current on start-up. The external SS pin is used to tailor the soft-start for a specific application but is not required for all applications and can be left open when not needed. When used a current source charges the external soft-start capacitor C_{SS} until it reaches its typical clamp voltage, V_{SS} . The soft-start time can be estimated as:

$$T_{SS} = C_{SS} \cdot V_{SS} / I_{SS}$$

THERMAL SHUTDOWN

The LM3310 includes thermal shutdown. If the die temperature reaches 145°C the device will shut down until it cools to a safe temperature at which point the device will resume operation. If the adverse condition that is heating the device is not removed (ambient temperature too high, short circuit conditions, etc...) the device will continue to cycle on and off to keep the die temperature below 145°C. The thermal shutdown has approximately 20°C of hysteresis. When in thermal shutdown the boost regulator, Op-Amp, and GPM blocks will all be disabled.

INPUT UNDER-VOLTAGE PROTECTION

The LM3310 includes input under-voltage protection (UVP). The purpose of the UVP is to protect the device both during start-up and during normal operation from trying to operate with insufficient input voltage. During start-up using a ramping input voltage the UVP circuitry ensures that the device does not begin switching until the input voltage reaches the UVP On threshold. If the input voltage is present and the shutdown

pin is pulled high the UVP circuitry will prevent the device from switching if the input voltage present is lower than the UVP On threshold. During normal operation the UVP circuitry will disable the device if the input voltage falls below the UVP Off threshold for any reason. In this case the device will not turn back on until the UVP On threshold voltage is exceeded.

OPERATIONAL AMPLIFIER

Compensation:

The architecture used for the amplifier in the LM3310 requires external compensation on the output. Depending on the equivalent resistive and capacitive distributed load of the TFT-LCD panel, external components at the amplifier outputs may or may not be necessary. If the capacitance presented by the load is equal to or greater than an equivalent distributive load of 50Ω in series with 4.7nF no external components are needed as the TFT-LCD panel will act as compensation itself. Distributed resistive and capacitive loads enhance stability and increase performance of the amplifiers. If the capacitance and resistance presented by the load is less than 50Ω in series with 4.7nF , external components will be required as the load itself will not ensure stability. No external compensation in this case will lead to oscillation of the amplifier and an increase in power consumption. A good choice for compensation in this case is to add a 50Ω in series with a 4.7nF capacitor from the output of the amplifier to ground. This allows for driving zero to infinite capacitance loads with no oscillations, minimal overshoot, and a higher slew rate than using a single large capacitor. The high phase margin created by the external compensation will guarantee stability and good performance for all conditions.

Layout and Filtering considerations:

When the power supply for the amplifiers (AV_{IN}) is connected to the output of the switching regulator, the output ripple of the regulator will produce ripple at the output of the amplifiers. This can be minimized by directly bypassing the AV_{IN} pin to ground with a low ESR ceramic capacitor. For best noise reduction a resistor on the order of 5Ω to 20Ω from the supply being used to the AV_{IN} pin will create an RC filter and give you a cleaner supply to the amplifier. The bypass capacitor should be placed as close to the AV_{IN} pin as possible and connected directly to the AGND plane.

For best noise immunity all bias and feedback resistors should be in the low $k\Omega$ range due to the high input impedance of the amplifier. It is good practice to use a small capacitance at the high impedance input terminals as well to reduce noise susceptibility. All resistors and capacitors should be placed as close to the input pins as possible.

Special care should also be taken in routing of the PCB traces. All traces should be as short and direct as possible. The output pin trace must never be routed near any trace going to the positive input. If this happens cross talk from the output trace to the positive input trace will cause the circuit to oscillate.

The op-amp is not a three terminal device it has 5 terminals: positive voltage power pin, AGND, positive input, negative input, and the output. The op-amp "routes" current from the power input pin and AGND to the output pin. So in effect an opamp has not two inputs but four, all of which must be kept noise free relative to the external circuits which are being driven by the op-amp. The current from the power pins goes through the output pin and into the load and feedback loop. The current exiting the load and feedback loops then must have a return path back to the op-amp power supply pins. Ideally this return path must follow the same path as the output pin trace to the load. Any deviation that makes the loop

area larger between the output current path and the return current path adds to the probability of noise pick up.

GATE PULSE MODULATION

The Gate Pulse Modulation (GPM) block is designed to provide a modulated voltage to the gate driver circuitry of a TFT LCD display. Operation is best understood by referring to the GPM block diagram in the *Block Diagrams* section, the drawing in *Figure 2* and the transient waveforms in *Figure 3* and *Figure 4*.

There are two control signals in the GPM block, VDPM and VFLK. VDPM is the enable pin for the GPM block. If VDPM is high, the GPM block is active and will respond to the VFLK drive signal from the timing controller. However, if VDPM is low, the GPM block will be disabled and both PMOS switches P2 and P3 will be turned off. The VGHM node will be discharged through a $1k\Omega$ resistor and the NMOS switch N2.

When VDPM is high, typical waveforms for the GPM block can be seen in *Figure 2*. The pin VGH is typically driven by a 2x or 3x charge pump. In most cases, the 2x or 3x charge pump is a discrete solution driven from the SW pin and the output of the boost switching regulator. When VFLK is high, the PMOS switch P2 is turned on and the PMOS switch P3 is turned off. With P2 on, the VGHM pin is pulled to the same voltage applied to the VGH pin. This provides a high gate drive voltage, $VGHM_{MAX}$, and can source current to the gate drive circuitry. When VFLK is high, NMOS switch N3 is on which discharges the capacitor CE.

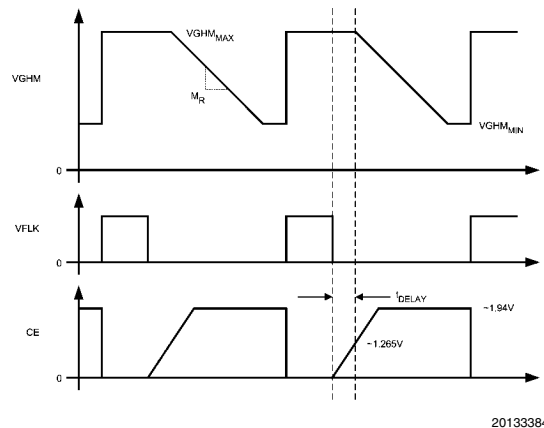

FIGURE 2.

When VFLK is low, the NMOS switch N3 is turned off which allows current to charge the C_E capacitor. This creates a delay, t_{DELAY} , given by the following equations:

$$t_{DELAY} \approx 1.265V(C_E + 7pF)/I_{CE}$$

When the voltage on CE reaches about $1.265V$ and the VFLK signal is low, the PMOS switch P2 will turn off and the PMOS switch P3 will turn on connecting resistor R3 to the VGHM pin through P3. This will discharge the voltage at VGHM at some rate determined by R3 creating a slope, M_R , as shown in *Figure 2*. The VGHM pin is no longer a current source, it is now sinking current from the gate drive circuitry.

As VGHM is discharged through R3, the comparator connected to the pin V_{DD} monitors the VGHM voltage. PMOS switch P3 will turn off when the following is true:

$$VGHM_{MIN} \approx 10V_X R_2 / (R_1 + R_2)$$

where V_X is some voltage connected to the resistor divider on pin V_{DD} . V_X is typically connected to the output of the boost switching regulator. When PMOS switch P3 turns off, VGHM will be high impedance until the VFLK pin is high again.

Figure 3 and Figure 4 give typical transient waveforms for the GPM block. Waveform (1) is the VGHM pin, (2) is the VFLK and (3) is the VDPM. The output of the boost switching regulator is operating at 8.5V and there is a 3x discrete charge pump (~23.5V) supplying the VGH pin. In Figure 3 and Figure 4, the VGHM pin is driving a purely capacitive load, 4.7nF. The value of resistor R1 is 15kohm, R2 is 1.1kΩ and R3 is 750Ω. In both transient plots, there is no C_E delay capacitor.

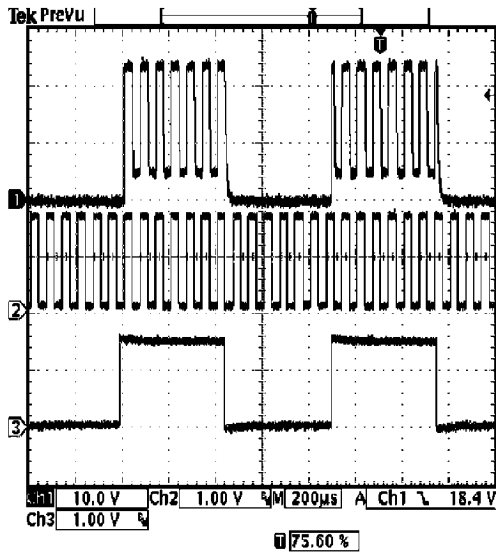

FIGURE 3.

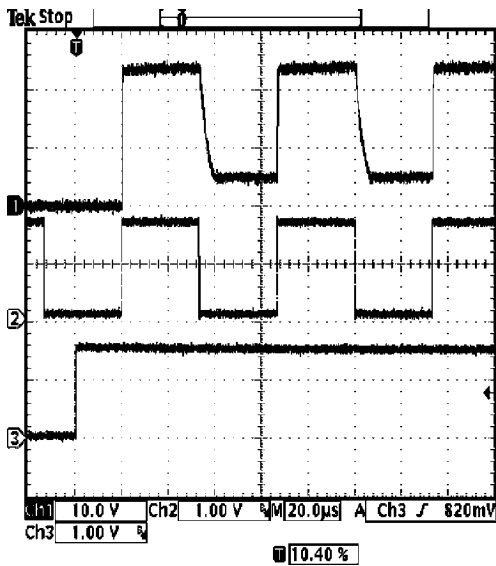

FIGURE 4.

In the GPM block diagram, a signal called “Reset” is shown. This signal is generated from the V_{IN} under-voltage lockout, thermal shutdown, or the SHDN pin. If the V_{IN} supply voltage drops below 2.3V, typically, then the GPM block will be dis-

abled and the VGHM pin will discharge through NMOS switch N2 and the 1kΩ resistor. This applies also if the junction temperature of the device exceeds 145°C or if the SHDN signal is low. As shown in the block diagram, both VDPM and VFLK have internal 350kΩ pull down resistors. This puts both VDPM and VFLK in normally “off” states. Typical VDPM and VFLK pin currents can be found in the *Typical Performance Characteristics* section.

INTRODUCTION TO COMPENSATION (BOOST CONVERTER)

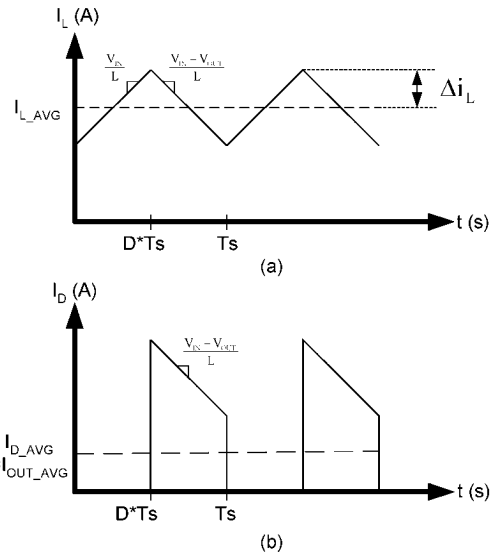

FIGURE 5. (a) Inductor current. (b) Diode current.

The LM3310 is a current mode PWM boost converter. The signal flow of this control scheme has two feedback loops, one that senses switch current and one that senses output voltage.

To keep a current programmed control converter stable above duty cycles of 50%, the inductor must meet certain criteria. The inductor, along with input and output voltage, will determine the slope of the current through the inductor (see Figure 5 (a)). If the slope of the inductor current is too great, the circuit will be unstable above duty cycles of 50%. A 10μH inductor is recommended for most 660 kHz applications, while a 4.7μH inductor may be used for most 1.28 MHz applications. If the duty cycle is approaching the maximum of 85%, it may be necessary to increase the inductance by as much as 2X. See *Inductor and Diode Selection* for more detailed inductor sizing.

The LM3310 provides a compensation pin (V_C) to customize the voltage loop feedback. It is recommended that a series combination of R_C and C_C be used for the compensation network, as shown in the typical application circuit. For any given application, there exists a unique combination of R_C and C_C that will optimize the performance of the LM3310 circuit in terms of its transient response. The series combination of R_C and C_C introduces a pole-zero pair according to the following equations:

$$f_{zC} = \frac{1}{2\pi R_C C_C} \text{ Hz}$$

$$f_{PC} = \frac{1}{2\pi(R_C + R_O)C_C} \text{ Hz}$$

where R_O is the output impedance of the error amplifier, approximately $900\text{k}\Omega$. For most applications, performance can be optimized by choosing values within the range $5\text{k}\Omega \leq R_C \leq 100\text{k}\Omega$ (R_C can be up to $200\text{k}\Omega$ if C_{C2} is used, see *High Output Capacitor ESR Compensation*) and $68\text{pF} \leq C_C \leq 4.7\text{nF}$. Refer to the *Applications Information* section for recommended values for specific circuits and conditions. Refer to the *Compensation* section for other design requirement.

COMPENSATION

This section will present a general design procedure to help insure a stable and operational circuit. The designs in this datasheet are optimized for particular requirements. If different conversions are required, some of the components may need to be changed to ensure stability. Below is a set of general guidelines in designing a stable circuit for continuous conduction operation, in most all cases this will provide for stability during discontinuous operation as well. The power components and their effects will be determined first, then the compensation components will be chosen to produce stability.

INDUCTOR AND DIODE SELECTION

Although the inductor sizes mentioned earlier are fine for most applications, a more exact value can be calculated. To ensure stability at duty cycles above 50%, the inductor must have some minimum value determined by the minimum input voltage and the maximum output voltage. This equation is:

$$L > \frac{V_{IN}R_{DSON}}{0.144 f_s} \left[\frac{D}{D'} - 1 \right] \text{ (in H)}$$

where f_s is the switching frequency, D is the duty cycle, and R_{DSON} is the ON resistance of the internal switch taken from the graph " R_{DSON} vs. V_{IN} " in the *Typical Performance Characteristics* section. This equation is only good for duty cycles greater than 50% ($D > 0.5$), for duty cycles less than 50% the recommended values may be used. The value given by this equation is the inductance necessary to suppress sub-harmonic oscillations. In some cases the value given by this equation may be too small for a given application. In this case the average inductor current and the inductor current ripple must be considered.

The corresponding inductor current ripple, average inductor current, and peak inductor current as shown in *Figure 5 (a)* is given by:

$$\Delta i_L = \frac{V_{IN}D}{2Lfs} \text{ (in Amps)}$$

$$i_{L(AVE)} \approx \frac{I_{OUT}}{\eta D'}$$

$$i_{L(PEAK)} \approx i_{L(AVE)} + \Delta i_L$$

Continuous conduction mode occurs when Δi_L is less than the average inductor current and discontinuous conduction mode occurs when Δi_L is greater than the average inductor current. Care must be taken to make sure that the switch will not reach its current limit during normal operation. The inductor must

also be sized accordingly. It should have a saturation current rating higher than the peak inductor current expected. The output voltage ripple is also affected by the total ripple current.

The output diode for a boost regulator must be chosen correctly depending on the output voltage and the output current. The typical current waveform for the diode in continuous conduction mode is shown in *Figure 5 (b)*. The diode must be rated for a reverse voltage equal to or greater than the output voltage used. The average current rating must be greater than the maximum load current expected, and the peak current rating must be greater than the peak inductor current. During short circuit testing, or if short circuit conditions are possible in the application, the diode current rating must exceed the switch current limit. Using Schottky diodes with lower forward voltage drop will decrease power dissipation and increase efficiency.

DC GAIN AND OPEN-LOOP GAIN

Since the control stage of the converter forms a complete feedback loop with the power components, it forms a closed-loop system that must be stabilized to avoid positive feedback and instability. A value for open-loop DC gain will be required, from which you can calculate, or place, poles and zeros to determine the crossover frequency and the phase margin. A high phase margin (greater than 45°) is desired for the best stability and transient response. For the purpose of stabilizing the LM3310, choosing a crossover point well below where the right half plane zero is located will ensure sufficient phase margin.

To ensure a bandwidth of $\frac{1}{2}$ or less of the frequency of the RHP zero, calculate the open-loop DC gain, A_{DC} . After this value is known, you can calculate the crossover visually by placing a -20dB/decade slope at each pole, and a $+20\text{dB/decade}$ slope for each zero. The point at which the gain plot crosses unity gain, or 0dB , is the crossover frequency. If the crossover frequency is less than $\frac{1}{2}$ the RHP zero, the phase margin should be high enough for stability. The phase margin can also be improved by adding C_{C2} as discussed later in this section. The equation for A_{DC} is given below with additional equations required for the calculation:

$$A_{DC(\text{dB})} = 20 \log_{10} \left\{ \left(\frac{R_{FB2}}{R_{FB1} + R_{FB2}} \right) \frac{g_m R_O D'}{R_{DSON}} \left\{ \frac{\omega_c L_{\text{eff}}}{R_L} // \frac{1}{R_L} \right\} \right\} \text{ (in dB)}$$

$$\omega_c \approx \frac{2fs}{nD'} \text{ (in rad/s)}$$

$$L_{\text{eff}} = \frac{L}{(D')^2}$$

$$n = 1 + \frac{2mc}{m1} \text{ (no unit)}$$

$$mc \approx 0.072fs \text{ (in V/s)}$$

$$m1 \approx \frac{V_{IN}R_{DSON}}{L} \text{ (in V/s)}$$

where R_L is the minimum load resistance, V_{IN} is the minimum input voltage, g_m is the error amplifier transconductance found in the *Electrical Characteristics* table, and R_{DSON} is the value chosen from the graph " $\text{NMOS } R_{DSON}$ vs. Input Voltage" in the *Typical Performance Characteristics* section.

INPUT AND OUTPUT CAPACITOR SELECTION

The switching action of a boost regulator causes a triangular voltage waveform at the input. A capacitor is required to reduce the input ripple and noise for proper operation of the regulator. The size used is dependant on the application and board layout. If the regulator will be loaded uniformly, with very little load changes, and at lower current outputs, the input capacitor size can often be reduced. The size can also be reduced if the input of the regulator is very close to the source output. The size will generally need to be larger for applications where the regulator is supplying nearly the maximum rated output or if large load steps are expected. A minimum value of 10 μ F should be used for the less stressful conditions while a 22 μ F to 47 μ F capacitor may be required for higher power and dynamic loads. Larger values and/or lower ESR may be needed if the application requires very low ripple on the input source voltage.

The choice of output capacitors is also somewhat arbitrary and depends on the design requirements for output voltage ripple. It is recommended that low ESR (Equivalent Series Resistance, denoted R_{ESR}) capacitors be used such as ceramic, polymer electrolytic, or low ESR tantalum. Higher ESR capacitors may be used but will require more compensation which will be explained later on in the section. The ESR is also important because it determines the peak to peak output voltage ripple according to the approximate equation:

$$\Delta V_{OUT} \approx 2\Delta I_L R_{ESR} \text{ (in Volts)}$$

A minimum value of 10 μ F is recommended and may be increased to a larger value. After choosing the output capacitor you can determine a pole-zero pair introduced into the control loop by the following equations:

$$f_{P1} = \frac{1}{2\pi(R_{ESR} + R_L)C_{OUT}} \text{ (in Hz)}$$

$$f_{Z1} = \frac{1}{2\pi R_{ESR} C_{OUT}} \text{ (in Hz)}$$

Where R_L is the minimum load resistance corresponding to the maximum load current. The zero created by the ESR of the output capacitor is generally very high frequency if the ESR is small. If low ESR capacitors are used it can be neglected. If higher ESR capacitors are used see the *High Output Capacitor ESR Compensation* section. Some suitable capacitor vendors include Vishay, Taiyo-Yuden, and TDK.

RIGHT HALF PLANE ZERO

A current mode control boost regulator has an inherent right half plane zero (RHP zero). This zero has the effect of a zero in the gain plot, causing an imposed +20dB/decade on the rolloff, but has the effect of a pole in the phase, subtracting another 90° in the phase plot. This can cause undesirable effects if the control loop is influenced by this zero. To ensure the RHP zero does not cause instability issues, the control loop should be designed to have a bandwidth of less than 1/2 the frequency of the RHP zero. This zero occurs at a frequency of:

$$\text{RHPzero} = \frac{V_{OUT}(D')^2}{2\pi I_{LOAD} L} \text{ (in Hz)}$$

where I_{LOAD} is the maximum load current.

SELECTING THE COMPENSATION COMPONENTS

The first step in selecting the compensation components R_C and C_C is to set a dominant low frequency pole in the control loop. Simply choose values for R_C and C_C within the ranges given in the *Introduction to Compensation* section to set this pole in the area of 10Hz to 500Hz. The frequency of the pole created is determined by the equation:

$$f_{PC} = \frac{1}{2\pi(R_C + R_O)C_C} \text{ (in Hz)}$$

where R_O is the output impedance of the error amplifier, approximately 900k Ω . Since R_C is generally much less than R_O , it does not have much effect on the above equation and can be neglected until a value is chosen to set the zero f_{ZC} . f_{ZC} is created to cancel out the pole created by the output capacitor, f_{P1} . The output capacitor pole will shift with different load currents as shown by the equation, so setting the zero is not exact. Determine the range of f_{P1} over the expected loads and then set the zero f_{ZC} to a point approximately in the middle. The frequency of this zero is determined by:

$$f_{ZC} = \frac{1}{2\pi C_C R_C} \text{ (in Hz)}$$

Now R_C can be chosen with the selected value for C_C . Check to make sure that the pole f_{PC} is still in the 10Hz to 500Hz range, change each value slightly if needed to ensure both component values are in the recommended range.

HIGH OUTPUT CAPACITOR ESR COMPENSATION

When using an output capacitor with a high ESR value, or just to improve the overall phase margin of the control loop, another pole may be introduced to cancel the zero created by the ESR. This is accomplished by adding another capacitor, C_{C2} , directly from the compensation pin V_C to ground, in parallel with the series combination of R_C and C_C . The pole should be placed at the same frequency as f_{Z1} , the ESR zero. The equation for this pole follows:

$$f_{PC2} = \frac{1}{2\pi C_{C2}(R_C // R_C)} \text{ (in Hz)}$$

To ensure this equation is valid, and that C_{C2} can be used without negatively impacting the effects of R_C and C_C , f_{PC2} must be greater than 10 f_{ZC} .

CHECKING THE DESIGN

With all the poles and zeros calculated the crossover frequency can be checked as described in the section *DC Gain and Open-loop Gain*. The compensation values can be changed a little more to optimize performance if desired. This is best done in the lab on a bench, checking the load step response with different values until the ringing and overshoot on the output voltage at the edge of the load steps is minimal. This should produce a stable, high performance circuit. For improved transient response, higher values of R_C should be chosen. This will improve the overall bandwidth which makes the regulator respond more quickly to transients. If more detail is required, or the most optimum performance is desired, refer to a more in depth discussion of compensating current mode DC/DC switching regulators.

POWER DISSIPATION

The output power of the LM3310 is limited by its maximum power dissipation. The maximum power dissipation is determined by the formula

$$P_D = (T_{jmax} - T_A) / \theta_{JA}$$

where T_{jmax} is the maximum specified junction temperature (125°C), T_A is the ambient temperature, and θ_{JA} is the thermal resistance of the package.

LAYOUT CONSIDERATIONS

The input bypass capacitor C_{IN} , as shown in the typical operating circuit, must be placed close to the IC. This will reduce copper trace resistance which effects input voltage ripple of the IC. For additional input voltage filtering, a 100nF bypass capacitor can be placed in parallel with C_{IN} , close to the V_{IN} pin, to shunt any high frequency noise to ground. The output capacitor, C_{OUT} , should also be placed close to the IC. Any copper trace connections for the C_{OUT} capacitor can increase

the series resistance, which directly effects output voltage ripple. The feedback network, resistors R_{FB1} and R_{FB2} , should be kept close to the FB pin, and away from the inductor, to minimize copper trace connections that can inject noise into the system. R_E and C_E should also be close to the RE and CE pins to minimize noise in the GPM circuitry. Trace connections made to the inductor and schottky diode should be minimized to reduce power dissipation and increase overall efficiency. For more detail on switching power supply layout considerations see Application Note AN-1149: *Layout Guidelines for Switching Power Supplies*.

For Op-Amp layout please refer to the *Operational Amplifier* section.

Figure 6, Figure 7, and Figure 8 in the Application Information section following show the schematic and an example of a good layout as used in the LM3310/11 evaluation board.

Application Information

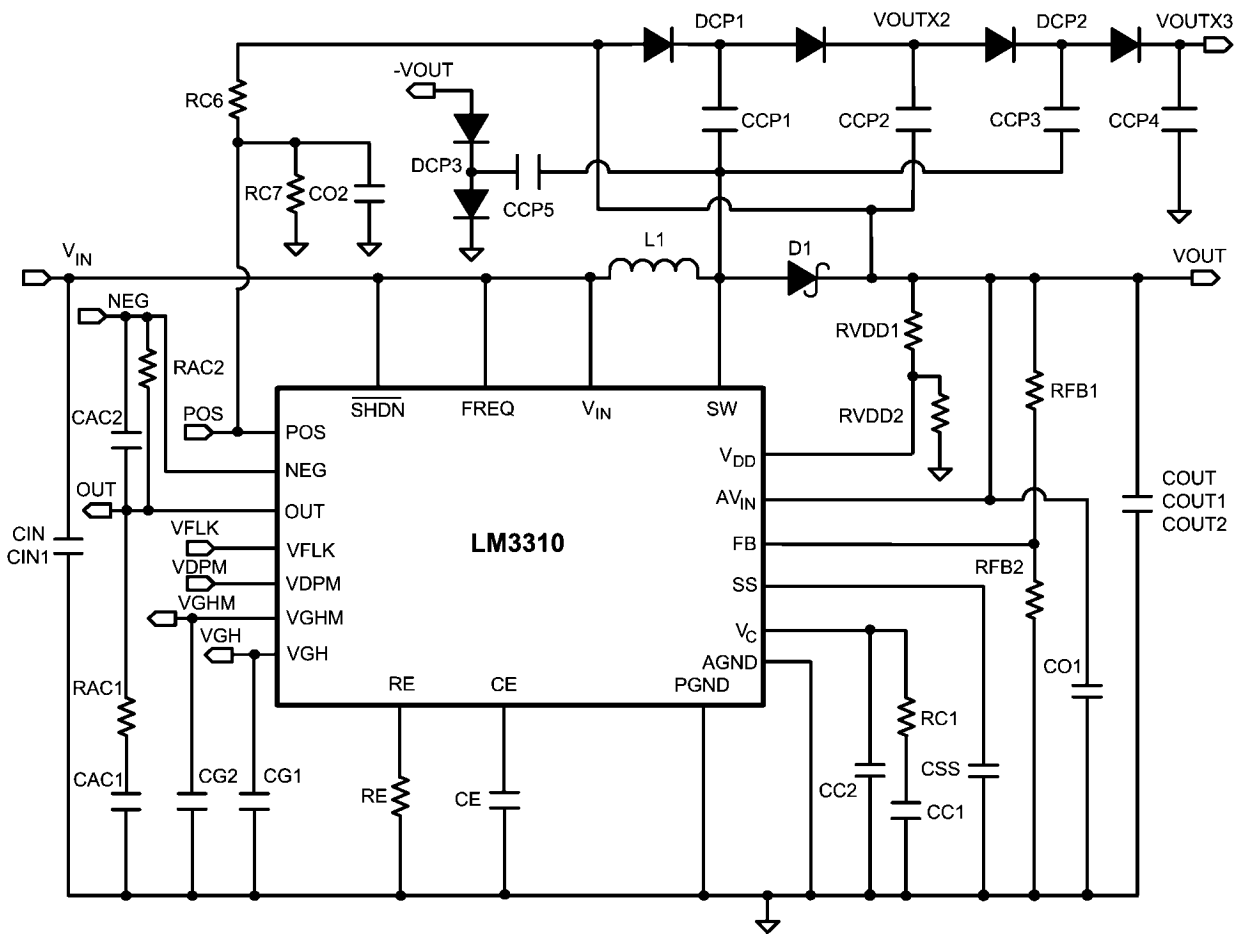
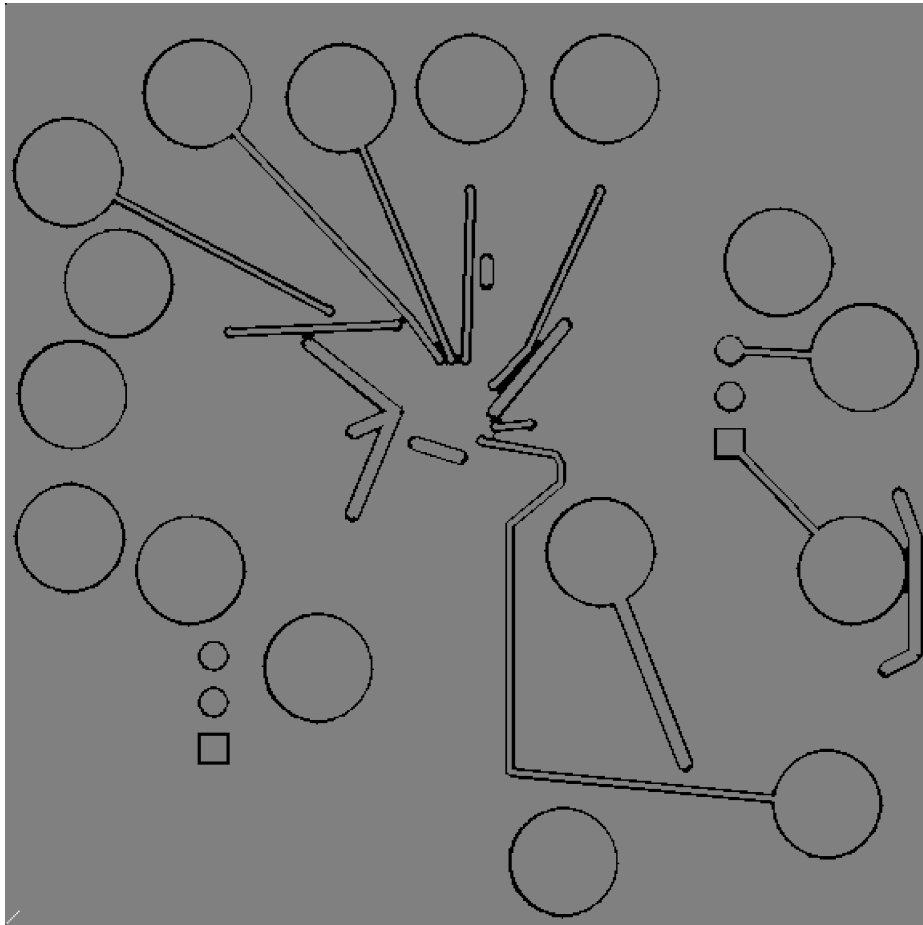

FIGURE 6. Evaluation Board Schematic

20133323



20133325

FIGURE 8. Evaluation Board Layout (bottom layer)

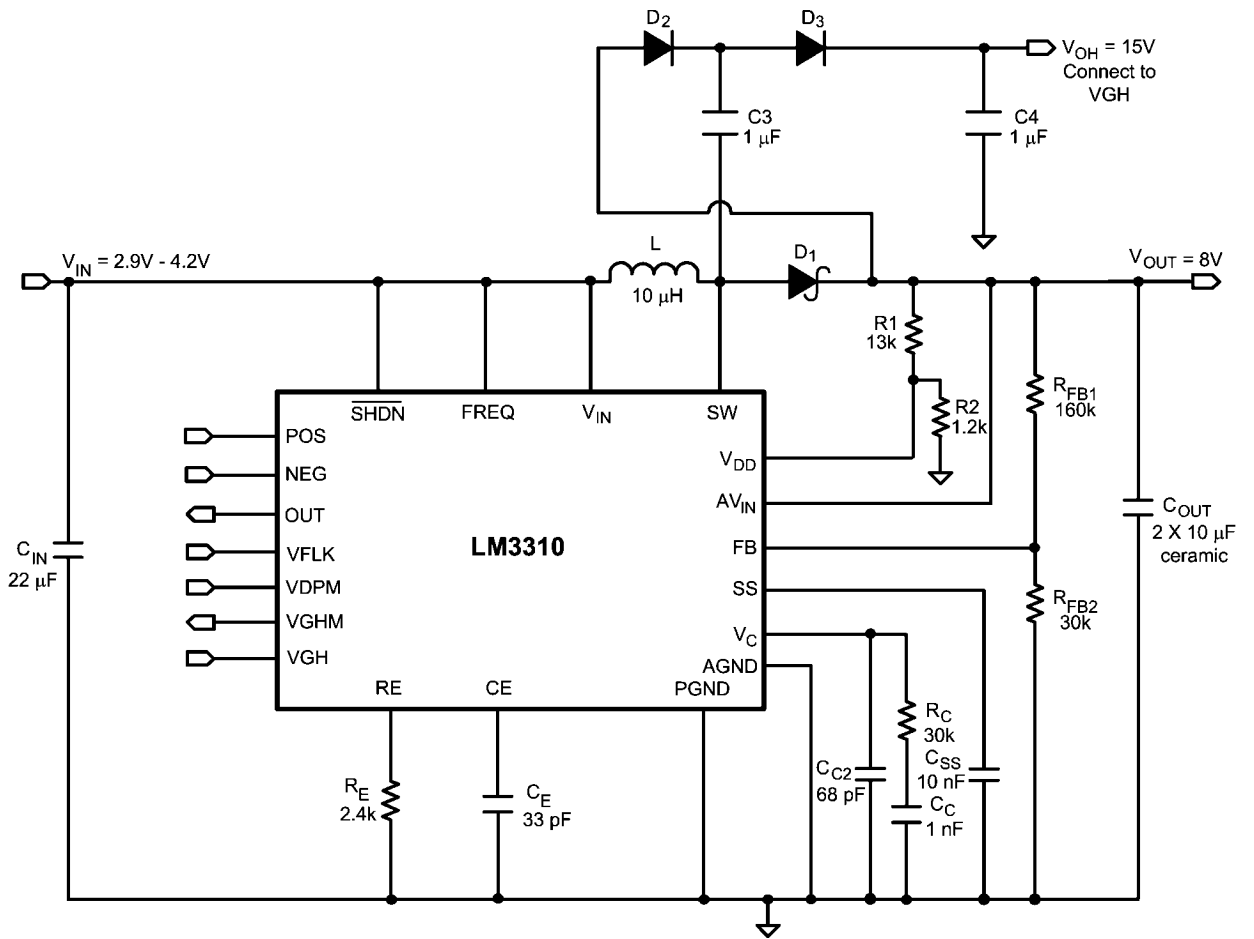

20133329

FIGURE 9. Li-Ion to 8V, 1.28MHz Application

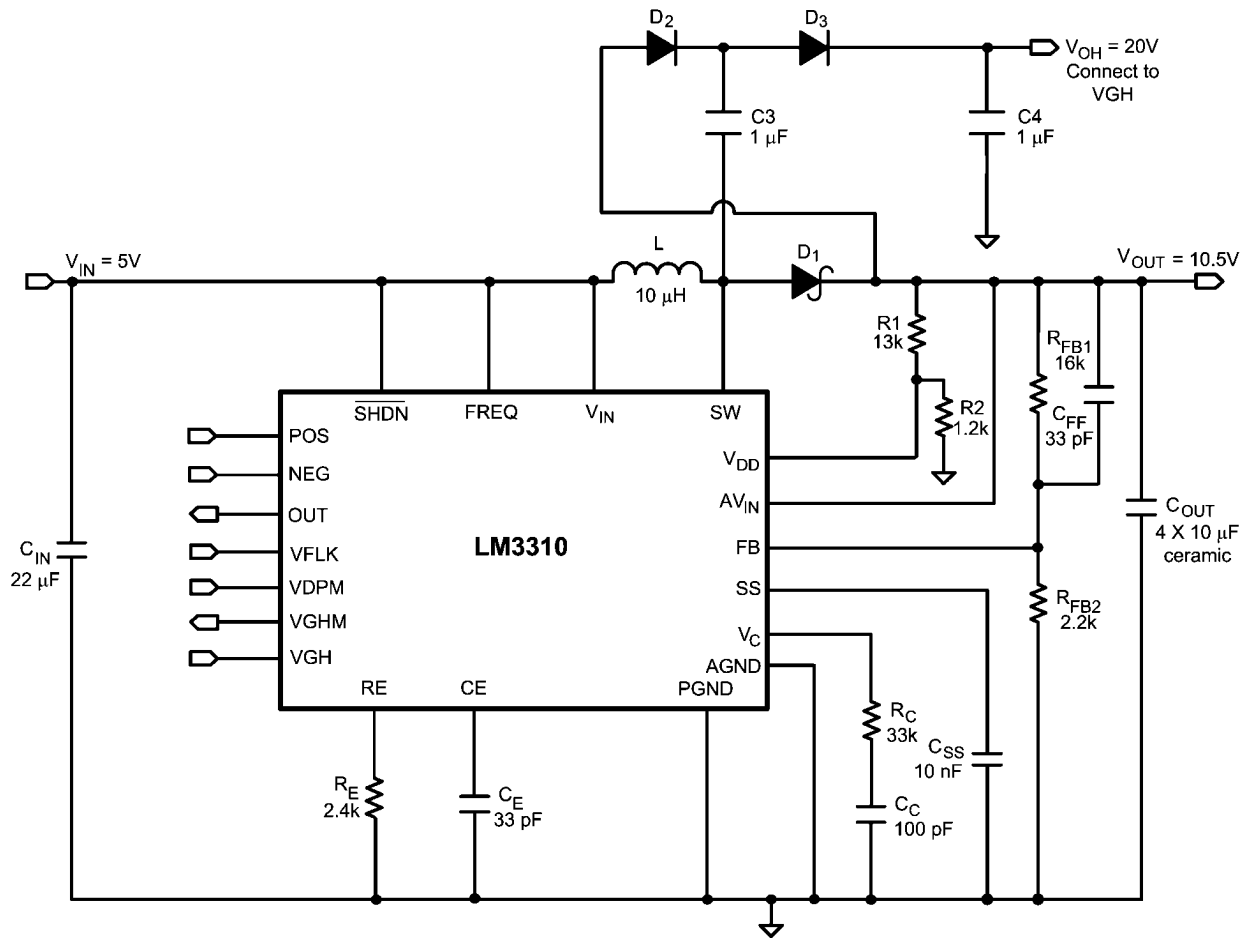

20133330

FIGURE 10. 5V to 10.5V, 1.28MHz Application

Some Recommended Inductors (Others May Be Used)

Manufacturer	Inductor	Contact Information
Coilcraft	DO3316 and DT3316 series	www.coilcraft.com 800-3222645
TDK	SLF10145 series	www.component.tdk.com 847-803-6100
Pulse	P0751 and P0762 series	www.pulseeng.com
Sumida	CDRH8D28 and CDRH8D43 series	www.sumida.com

Some Recommended Input And Output Capacitors (Others May Be Used)

Manufacturer	Capacitor	Contact Information
Vishay Sprague	293D, 592D, and 595D series tantalum	www.vishay.com 407-324-4140
Taiyo Yuden	High capacitance MLCC ceramic	www.t-yuden.com 408-573-4150
Cornell Dubilier	ESRD series Polymer Aluminum Electrolytic SPV and AFK series V-chip series	www.cde.com
Panasonic	High capacitance MLCC ceramic EEJ-L series tantalum	www.panasonic.com

Notes

LM3310

Notes

For more National Semiconductor product information and proven design tools, visit the following Web sites at:

Products		Design Support	
Amplifiers	www.national.com/amplifiers	WEBENCH	www.national.com/webench
Audio	www.national.com/audio	Analog University	www.national.com/AU
Clock Conditioners	www.national.com/timing	App Notes	www.national.com/appnotes
Data Converters	www.national.com/adc	Distributors	www.national.com/contacts
Displays	www.national.com/displays	Green Compliance	www.national.com/quality/green
Ethernet	www.national.com/ethernet	Packaging	www.national.com/packaging
Interface	www.national.com/interface	Quality and Reliability	www.national.com/quality
LVDS	www.national.com/lvds	Reference Designs	www.national.com/refdesigns
Power Management	www.national.com/power	Feedback	www.national.com/feedback
Switching Regulators	www.national.com/switchers		
LDOs	www.national.com/ldo		
LED Lighting	www.national.com/led		
PowerWise	www.national.com/powerwise		
Serial Digital Interface (SDI)	www.national.com/sdi		
Temperature Sensors	www.national.com/tempsensors		
Wireless (PLL/VCO)	www.national.com/wireless		

THE CONTENTS OF THIS DOCUMENT ARE PROVIDED IN CONNECTION WITH NATIONAL SEMICONDUCTOR CORPORATION ("NATIONAL") PRODUCTS. NATIONAL MAKES NO REPRESENTATIONS OR WARRANTIES WITH RESPECT TO THE ACCURACY OR COMPLETENESS OF THE CONTENTS OF THIS PUBLICATION AND RESERVES THE RIGHT TO MAKE CHANGES TO SPECIFICATIONS AND PRODUCT DESCRIPTIONS AT ANY TIME WITHOUT NOTICE. NO LICENSE, WHETHER EXPRESS, IMPLIED, ARISING BY ESTOPPEL OR OTHERWISE, TO ANY INTELLECTUAL PROPERTY RIGHTS IS GRANTED BY THIS DOCUMENT.

TESTING AND OTHER QUALITY CONTROLS ARE USED TO THE EXTENT NATIONAL DEEMS NECESSARY TO SUPPORT NATIONAL'S PRODUCT WARRANTY. EXCEPT WHERE MANDATED BY GOVERNMENT REQUIREMENTS, TESTING OF ALL PARAMETERS OF EACH PRODUCT IS NOT NECESSARILY PERFORMED. NATIONAL ASSUMES NO LIABILITY FOR APPLICATIONS ASSISTANCE OR BUYER PRODUCT DESIGN. BUYERS ARE RESPONSIBLE FOR THEIR PRODUCTS AND APPLICATIONS USING NATIONAL COMPONENTS. PRIOR TO USING OR DISTRIBUTING ANY PRODUCTS THAT INCLUDE NATIONAL COMPONENTS, BUYERS SHOULD PROVIDE ADEQUATE DESIGN, TESTING AND OPERATING SAFEGUARDS.

EXCEPT AS PROVIDED IN NATIONAL'S TERMS AND CONDITIONS OF SALE FOR SUCH PRODUCTS, NATIONAL ASSUMES NO LIABILITY WHATSOEVER, AND NATIONAL DISCLAIMS ANY EXPRESS OR IMPLIED WARRANTY RELATING TO THE SALE AND/OR USE OF NATIONAL PRODUCTS INCLUDING LIABILITY OR WARRANTIES RELATING TO FITNESS FOR A PARTICULAR PURPOSE, MERCHANTABILITY, OR INFRINGEMENT OF ANY PATENT, COPYRIGHT OR OTHER INTELLECTUAL PROPERTY RIGHT.

LIFE SUPPORT POLICY

NATIONAL'S PRODUCTS ARE NOT AUTHORIZED FOR USE AS CRITICAL COMPONENTS IN LIFE SUPPORT DEVICES OR SYSTEMS WITHOUT THE EXPRESS PRIOR WRITTEN APPROVAL OF THE CHIEF EXECUTIVE OFFICER AND GENERAL COUNSEL OF NATIONAL SEMICONDUCTOR CORPORATION. As used herein:

Life support devices or systems are devices which (a) are intended for surgical implant into the body, or (b) support or sustain life and whose failure to perform when properly used in accordance with instructions for use provided in the labeling can be reasonably expected to result in a significant injury to the user. A critical component is any component in a life support device or system whose failure to perform can be reasonably expected to cause the failure of the life support device or system or to affect its safety or effectiveness.

National Semiconductor and the National Semiconductor logo are registered trademarks of National Semiconductor Corporation. All other brand or product names may be trademarks or registered trademarks of their respective holders.

Copyright© 2007 National Semiconductor Corporation

For the most current product information visit us at www.national.com



National Semiconductor Americas Customer Support Center
 Email: new.feedback@nsc.com
 Tel: 1-800-272-9959

National Semiconductor Europe Customer Support Center
 Fax: +49 (0) 180-530-85-86
 Email: europe.support@nsc.com
 Deutsch Tel: +49 (0) 69 9508 6208
 English Tel: +49 (0) 870 24 0 2171
 Français Tel: +33 (0) 1 41 91 8790

National Semiconductor Asia Pacific Customer Support Center
 Email: ap.support@nsc.com

National Semiconductor Japan Customer Support Center
 Fax: 81-3-5639-7507
 Email: jpn.feedback@nsc.com
 Tel: 81-3-5639-7560